

# PK(PD)25FG80/160

UL; E76102

《Features》

Power Thyristor/Diode Module PK25FG series are designed for various rectifier circuits and power controls. For your circuit application, following internal connections and wide voltage ratings up to 1600V are available. And electrically isolated mounting base make your mechanical design easy.

- $I_{T(AV)}$  25A,  $I_{T(RMS)}$  39A,  $I_{TSM}$  700A
- $di/dt$  100A/ $\mu$ s
- $dv/dt$  1000V/ $\mu$ s

《Applications》

- Various rectifiers / AC/DC motor drives / Heater controls / Light dimmers / Static switches

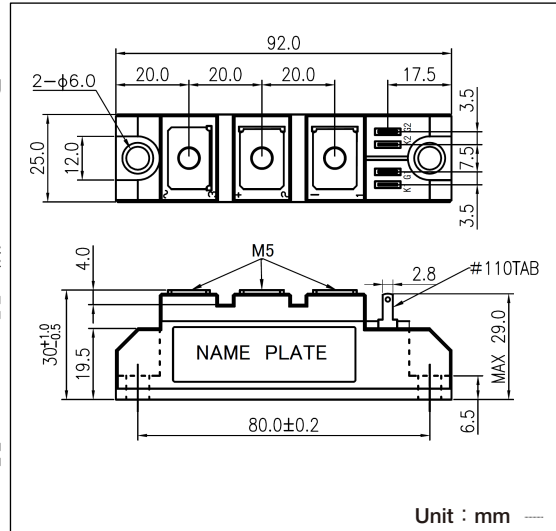
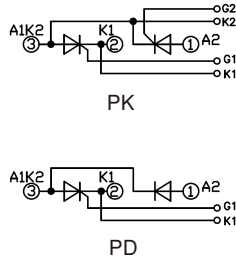

Unit : mm

■ Maximum Ratings ( $T_j=25^\circ\text{C}$  unless otherwise specified)

Item	Symbol	Unit	PK25FG80	PK25FG160
			PD25FG80	PD25FG160
*Repetitive Peak Reverse Voltage	$V_{RRM}$	V	800	1600
*Non-Repetitive Peak Reverse Voltage	$V_{RSM}$	V	960	1700
Repetitive Peak Off-state Voltage	$V_{DRM}$	V	800	1600

Item	Symbol	Unit	Ratings	Conditions
*Average On-state Current	$I_{T(AV)}$	A	25	Single phase, half wave 180° conduction, $T_c=81^\circ\text{C}$
*R.M.S. On-state Current	$I_{T(RMS)}$	A	39	Single phase, half wave 180° conduction, $T_c=81^\circ\text{C}$
*Surge On-state Current	$I_{TSM}$	A	640/700	1/2cycle, 50Hz/60Hz, Peak value, non-repetitive
* $I^2t$ (for fusing)	$I^2t$	$A^2s$	2870	Value for one cycle surge current
Peak Gate Power Dissipation	$P_{GM}$	W	10	
Average Gate Power Dissipation	$P_{G(AV)}$	W	1	
Peak Gate Current	$I_{FGM}$	A	3	
Peak Gate Voltage(Forward)	$V_{FGM}$	V	10	
Peak Gate Voltage(Reverse)	$V_{RGM}$	V	5	
Critical Rate of Rise of On-state Current	$di/dt$	A/ $\mu$ s	100	$I_G=100\text{mA}$ , $V_D=1/2V_{DRM}$ , $dI_G/dt=0.1\text{A}/\mu$ s
*Isolation Breakdown Voltage	$V_{ISO}$	V	2500	A.C. 1minute
*Operating Junction Temperature	$T_j$	$^\circ\text{C}$	-40 to +125	
*Storage Temperature	$T_{STG}$	$^\circ\text{C}$	-40 to +125	
Mounting Torque	Mounting M5	N·m (kgf·cm)	2.7(28)	Recommended Value 1.5 to 2.5 (15 to 25)
	Terminal M5		2.7(28)	Recommended Value 1.5 to 2.5 (15 to 25)
Mass		g	170	Typical value

■ Electrical Characteristics ( $T_j=25^\circ\text{C}$  unless otherwise specified)

Item	Symbol	Unit	Ratings	Conditions
Repetitive Peak Off-state Current,max.	$I_{DRM}$	mA	5	at $V_{DRM}$ , Single phase, half wave $T_j=125^\circ\text{C}$
*Repetitive Peak Reverse Current,max.	$I_{RRM}$	mA	5	at $V_{DRM}$ , Single phase, half wave $T_j=125^\circ\text{C}$
*Peak On-state Voltage,max.	$V_{TM}$	V	1.6	On-State Current 75A, Inst. measurement
Gate Trigger Current/Voltage, max.	$I_{GT}/V_{GT}$	mA	50/3	$I_T=1\text{A}$ , $V_D=6\text{V}$
Non-Trigger Gate Trigger Voltage,min.	$V_{GD}$	V	0.25	$T_j=125^\circ\text{C}$ , $V_D=1/2V_{DRM}$
Turn-on Time,max	$t_{gt}$	$\mu$ s	10	$I_T=25\text{A}$ , $I_G=100\text{mA}$ , $T_j=25^\circ\text{C}$ , $V_D=1/2V_{DRM}$ , $dI_G/dt=0.1\text{A}/\mu$ s
Critical Rate of Rise of Off-state Voltage,min.	$dv/dt$	V/ $\mu$ s	1000	$T_j=125^\circ\text{C}$ , $V_D=2/3V_{DRM}$ , Exponential wave
Holding Current	$I_H$	mA	50	$T_j=25^\circ\text{C}$
Latching Current	$I_L$	mA	100	$T_j=25^\circ\text{C}$
Thermal Resistance,max	$R_{th}$	$^\circ\text{C}/\text{W}$	1.1	Junction to case

\*mark : Thyristor and Diode part. No mark : Thyristor part

