

Take your product design to the next level with 3S SiC MOSFET



As previously introduced in the Winter 2021 edition of our newsletter, our 3S SiC MOSFET family is a strong candidate for multiple applications that can benefit considerably from its versatile features. In the core of this all-rounded power module is its high current capability. There are four main features that make the drain current one of the biggest in the market.

1.

2.

FCA150AC120:

$$I_D = \sqrt{\frac{T_{ch(max)} - T_c}{R_{DS(on)} \times \alpha \times R_{th(j-c)}}$$

$$I_D = \sqrt{\frac{150^\circ\text{C} - 90^\circ\text{C}}{4.5\text{m}\Omega \times 0.11^\circ\text{C/W}}} = \mathbf{348\text{A}}$$

*4.1mΩ at T_j=25°C
**α for T_j=150°C

1. Outstanding temperature management: The module's chip is optimized around operational temperature (90°C) and as the picture on the right shows, compared to that of our competitor's, the chip has a notably lower conduction loss even at higher degrees. This assures a strong support to your product design.

2. Remarkably low conduction loss [R_{ds(on)}]: Closely related to the first feature, the low conduction loss and the immense temperature management are made possible due to the size of the chip - the one used in our SiC MOSFET modules is one of the biggest in size on the market.

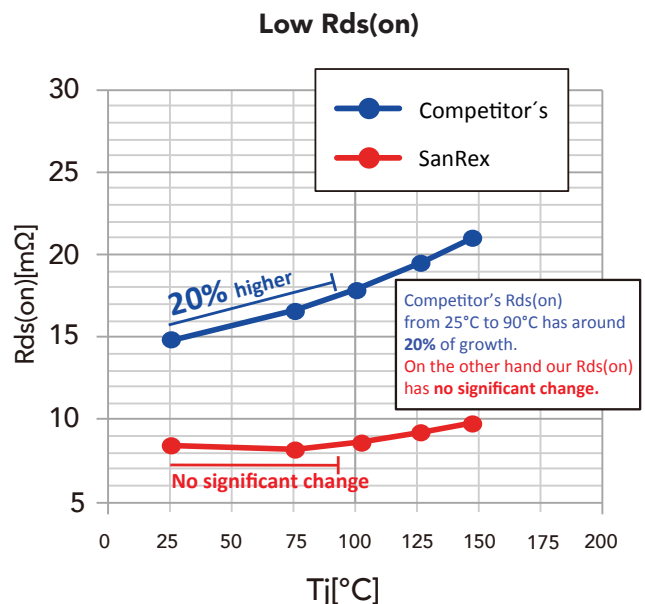

3. The DioMOS Chip: The chip is made by using a DioMOS* -structure: no external diode is needed since the diode function is integrated on the die along with the MOSFET chip. Compared to the area of the integrated diode, the area of the MOSFET chip is significantly bigger, which also enables the module to handle even higher current rates than the 150A capability of the diode chip alone**.

* Our SiC MOSFET features a FWD (flywheel diode), that is based on the function developed by Panasonic.

** Please see the formula 2 on the first page

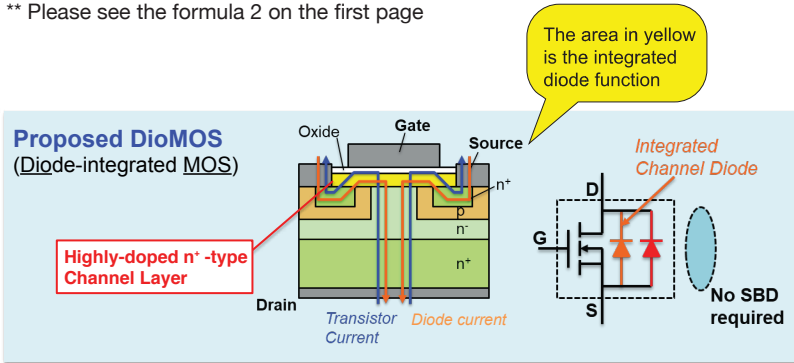

Source: Panasonic Industry, 3rd CIES Power Electronic Forum January 15, 2020.

4. Excellent thermal resistance [R_{th(j-c)}]: We have been able to minimize the overall material needed inside the module. The chosen materials have been carefully selected, using only the most advanced and best-fitting alternatives. The flatness of the bottom of the module has been optimized to easily manage it with a thermal sheet or grease.

Techno Block module cross section

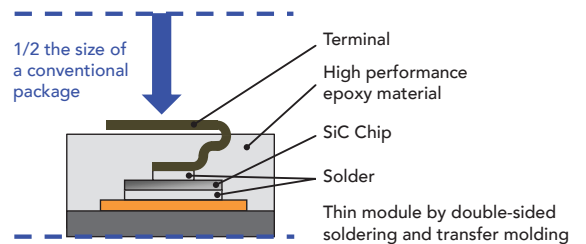

PROJECT: SanRex Amplifier (400-500 kHz) with SiC MOSFET



First-class sound quality achieved with SanRex's SiC MOSFET

Our 50A, 1200V SiC MOSFET device was used in an amplifier project that was completely built by using SanRex-only-made products. The steady and clear sound quality was made possible by utilizing the best qualities of our SiC MOSFET. Please find more about the details of the project from the following link:

<https://www.sanrex.fi/project-sanrex-amplifier-with-sic-mosfet>



The website of our Helsinki Branch Office was officially launched at the start of May 2021. Please visit the newly built website at www.sanrex.fi. SanRex Helsinki Branch Office is responsible of the sales to Europe, Middle East, Africa and Russia.