

TRIAC(Through Hole / Isolated)

TMG2D60F 5

(Sensitive Gate)

SanRex Triac TMG2D60F 5 is designed for full wave AC control applications. It can be used as an ON/OFF function or for phase control operation.

Typical Applications

- Home Appliances : Washing Machines, Vacuum Cleaners, Rice Cookers, Micro Wave Ovens, Hair Dryers, other control applications
- Industrial Use : SMPS, Copier Machines, Motor Controls, Dimmer, SSR, Heater Controls, Vending Machines, other control applications

Features

- $I_{T(RMS)}=2A$
- High Surge Current

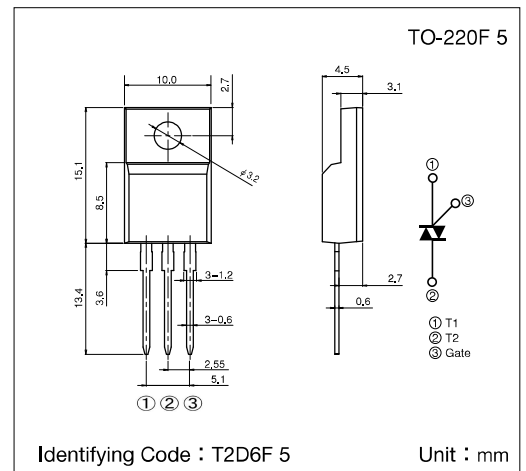

Maximum Ratings

($T_j=25^\circ C$ unless otherwise specified)

| Symbol | Item | Reference | Ratings | Unit |
|--------------|--------------------------------------|--|-----------------|------------|
| V_{DRM} | Repetitive Peak Off-State Voltage | | 600 | V |
| $I_{T(RMS)}$ | R.M.S. On-State Current | $T_c=105^\circ C$ | 2 | A |
| I_{TSM} | Surge On-State Current | One cycle, 50Hz/60Hz, Peak value, non-repetitive | 18/20 | A |
| I^2t | I^2t (for fusing) | | 1.67 | A^2s |
| P_{GM} | Peak Gate Power Dissipation | | 1.5 | W |
| $P_{G(AV)}$ | Average Gate Power Dissipation | | 0.1 | W |
| I_{GM} | Peak Gate Current | | 1 | A |
| V_{GM} | Peak Gate Voltage | | 7 | V |
| V_{ISO} | Isolation Breakdown Voltage (R.M.S.) | A.C. 1minute | 1500 | V |
| T_j | Operating Junction Temperature | | $-40 \sim +125$ | $^\circ C$ |
| T_{stg} | Storage Temperature | | $-40 \sim +150$ | $^\circ C$ |
| | Mass | | 2 | g |

Electrical Characteristics

| Symbol | Item | Reference | Ratings | | | Unit | |
|---------------|---|--|---------|------|------|--------------|---|
| | | | Min. | Typ. | Max. | | |
| I_{DRM} | Repetitive Peak Off-State Current | $V_D=V_{DRM}$, Single phase, half wave, $T_j=125^\circ C$ | | | 1 | mA | |
| V_{TM} | Peak On-State Voltage | $I_T=3A$, Inst. measurement | | | 1.6 | V | |
| I_{GT1}^+ | Gate Trigger Current | $V_D=6V$, $R_L=10\Omega$ | | | 5 | mA | |
| I_{GT1}^- | | | | | 5 | | |
| I_{GT3}^+ | | | | | 10 | | |
| I_{GT3}^- | | | | | 5 | | |
| V_{GT1}^+ | Gate Trigger Voltage | | | | | 1.5 | V |
| V_{GT1}^- | | | | | | 1.5 | |
| V_{GT3}^+ | | | | | | 2.0 | |
| V_{GT3}^- | | | | | | 1.5 | |
| V_{GD} | Non-Trigger Gate Voltage | $T_j=125^\circ C$, $V_D=1/2 V_{DRM}$ | 0.2 | | | V | |
| $(dv/dt)_c$ | Critical Rate of Rise of Off-State Voltage at Commutation | $T_j=125^\circ C$, $(di/dt)_c=-1A/ms$, $V_D=2/3 V_{DRM}$ | 3 | | | $V/\mu s$ | |
| I_H | Holding Current | | | 2 | | mA | |
| $R_{th(j-c)}$ | Thermal Resistance | Junction to case | | | 7.5 | $^\circ C/W$ | |
| $R_{th(j-a)}$ | | Junction to ambient | | | 50 | | |

Trigger mode of the triac

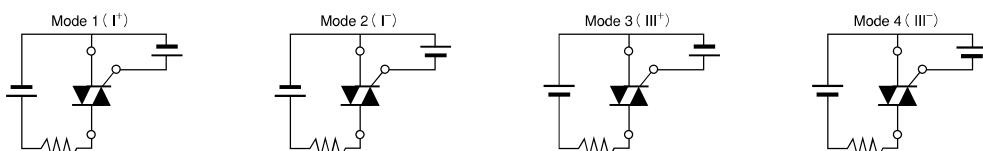

Gate Characteristics

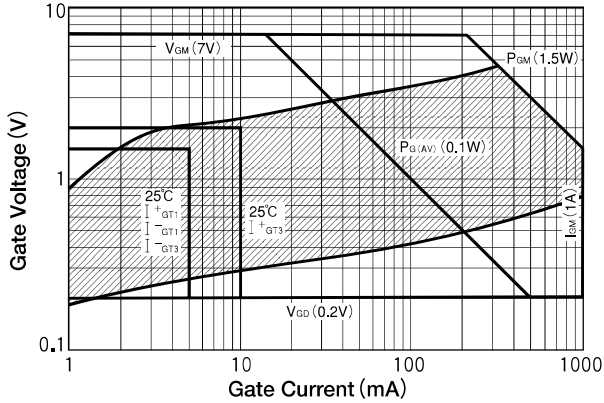

On-State Characteristics (MAX)

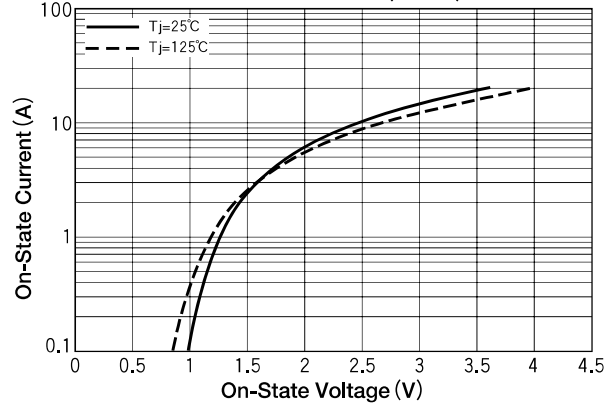

R.M.S. On-State Current vs Maximum Power Dissipation

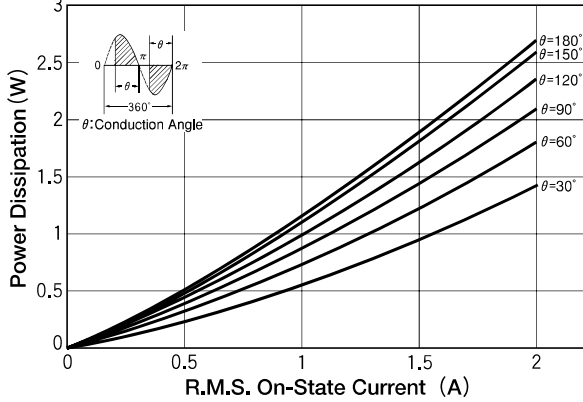

R.M.S. On-State Current vs Allowable Case Temperature

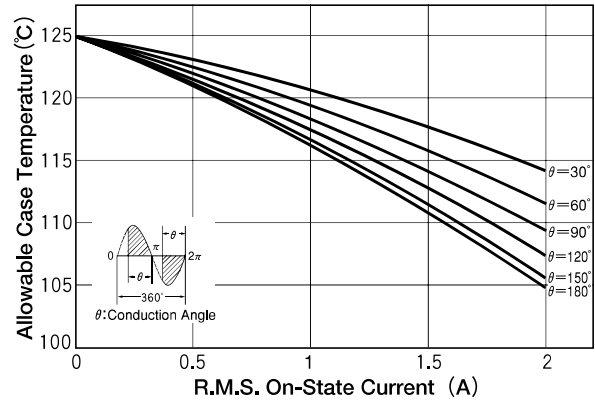

Surge On-State Current Rating (Non-Repetitive)

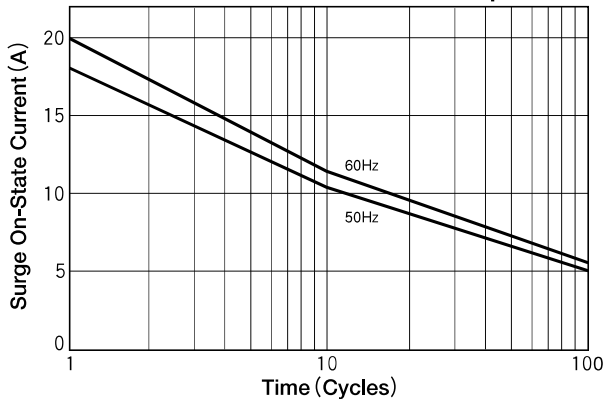

Transient Thermal Impedance

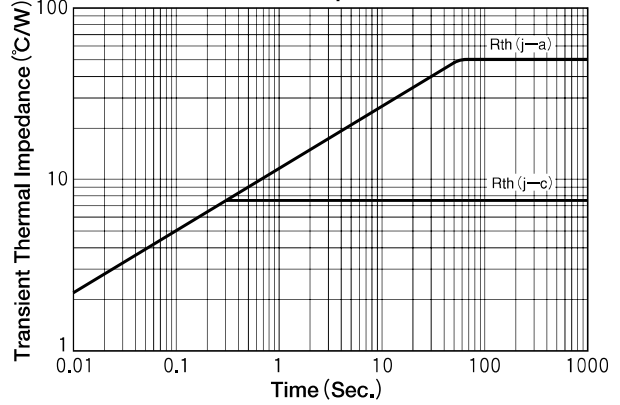

I_{GT} - T_j (Typical)

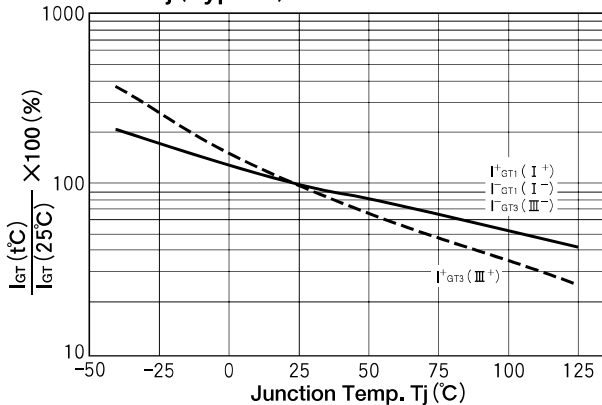

V_{GT} - T_j (Typical)

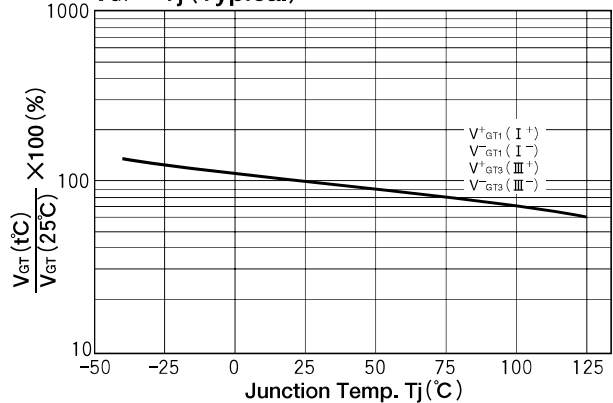

**R.M.S. On-State vs
Allowable Ambient Temperature**

