

PK(PD)55FG80/160

UL; E76102

《Features》

Power Thyristor/Diode Module PK55FG series are designed for various rectifier circuits and power controls. For your circuit application, following internal connections and wide voltage ratings up to 1600V are available. And electrically isolated mounting base make your mechanical design easy.

- $I_{T(AV)}$ 55A, $I_{T(RMS)}$ 86A, I_{TSM} 1300A
- di/dt 100A/ μ s
- dv/dt 1000V/ μ s

《Applications》

- Various rectifiers / AC/DC motor drives / Heater controls / Light dimmers / Static switches

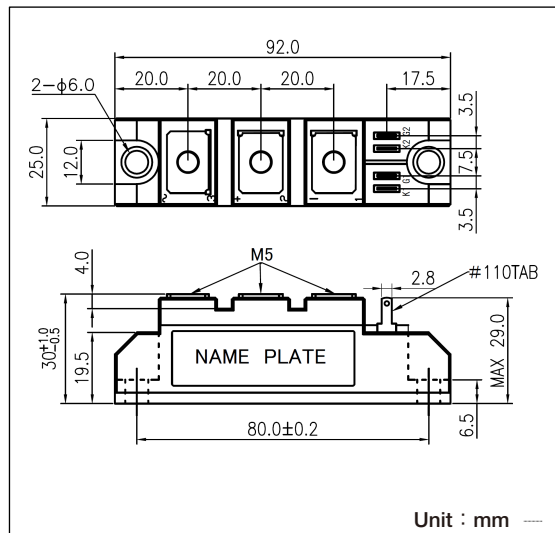
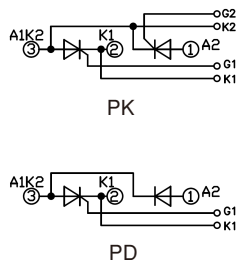

Unit : mm

■ Maximum Ratings ($T_j=25^\circ\text{C}$ unless otherwise specified)

Item	Symbol	Unit	PK55FG80	PK55FG160
			PD55FG80	PD55FG160
*Repetitive Peak Reverse Voltage	V_{RRM}	V	800	1600
*Non-Repetitive Peak Reverse Voltage	V_{RSM}	V	960	1700
Repetitive Peak Off-state Voltage	V_{DRM}	V	800	1600

Item	Symbol	Unit	Ratings	Conditions
*Average On-state Current	$I_{T(AV)}$	A	55	Single phase, half wave 180° conduction, $T_c=81^\circ\text{C}$
*R.M.S. On-state Current	$I_{T(RMS)}$	A	86	Single phase, half wave 180° conduction, $T_c=81^\circ\text{C}$
*Surge On-state Current	I_{TSM}	A	1190/1300	1/2 cycle, 50Hz/60Hz, Peak value, non-repetitive
* I^2t (for fusing)	I^2t	A^2s	7040	Value for one cycle surge current
Peak Gate Power Dissipation	P_{GM}	W	10	
Average Gate Power Dissipation	$P_{G(AV)}$	W	1	
Peak Gate Current	I_{FGM}	A	3	
Peak Gate Voltage(Forward)	V_{FGM}	V	10	
Peak Gate Voltage(Reverse)	V_{RGM}	V	5	
Critical Rate of Rise of On-state Current	di/dt	A/ μ s	100	$I_G=100\text{mA}$, $V_D=1/2V_{DRM}$, $dI_G/dt=0.1\text{A}/\mu$ s
*Isolation Breakdown Voltage	V_{ISO}	V	2500	A.C. 1minute
*Operating Junction Temperature	T_j	$^\circ\text{C}$	-40 to +125	
*Storage Temperature	T_{STG}	$^\circ\text{C}$	-40 to +125	
Mounting Torque	Mounting M5	N·m	2.7(28)	Recommended Value 1.5 to 2.5 (15 to 25)
	Terminal M5	($\text{kgf}\cdot\text{cm}$)	2.7(28)	Recommended Value 1.5 to 2.5 (15 to 25)
Mass		g	170	Typical value

■ Electrical Characteristics ($T_j=25^\circ\text{C}$ unless otherwise specified)

Item	Symbol	Unit	Ratings	Conditions
Repetitive Peak Off-state Current,max.	I_{DRM}	mA	15	at V_{DRM} , Single phase, half wave $T_j=125^\circ\text{C}$
*Repetitive Peak Reverse Current,max.	I_{RRM}	mA	15	at V_{DRM} , Single phase, half wave $T_j=125^\circ\text{C}$
*Peak On-state Voltage,max.	V_{TM}	V	1.6	On-State Current 165A, Inst.Measurement
Gate Trigger Current/Voltage, max.	I_{GT}/V_{GT}	mA	50/3	$I_T=1\text{A}$, $V_D=6\text{V}$
Non-Trigger Gate Trigger Voltage,min.	V_{GD}	V	0.25	$T_j=125^\circ\text{C}$, $V_D=1/2V_{DRM}$
Critical Rate of Rise of Off-state Voltage,min.	dv/dt	V/ μ s	1000	$T_j=125^\circ\text{C}$, $V_D=2/3V_{DRM}$, Exponential wave
Thermal Resistance,max	R_{th}	$^\circ\text{C}/\text{W}$	0.5	Junction to case

*mark : Thyristor and Diode part. No mark : Thyristor part

Gate Characteristics

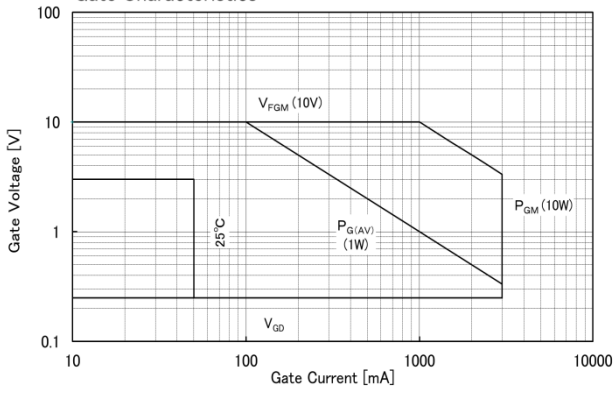

On-State Characteristics

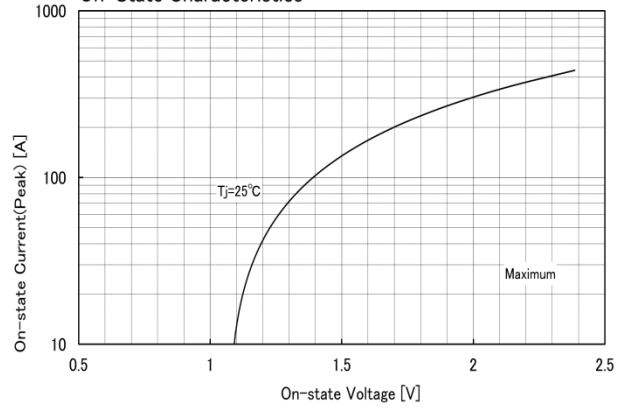

Surge On-State Current Rating <Non-Repetitive>

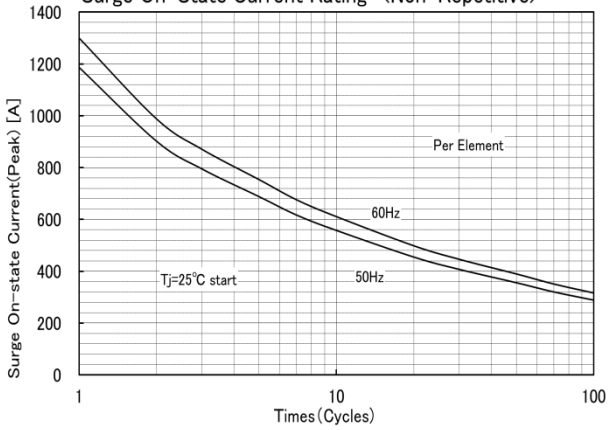

Transient Thermal Impedance

